

NOTES

1. THESE PLANS ARE BASED ON THE TOPOGRAPHIC AND BOUNDARY SURVEY PREPARED BY: GENTILE AND ASSOCIATES INC. 550 E. ST. CHARLES PLACE, LOMBARD, IL 60148 (630) 916-6262
2. ALL RADIUS DIMENSIONS ARE TO BACK OF CURB.
3. SEE ARCH. PLANS FOR EXACT BUILDING DIMENSIONS.
4. ALL STRIPING TO BE 4" YELLOW PAINT UNLESS OTHERWISE NOTED.

SITE DATA

TOTAL LOT AREA (ZONED C3) = 66,966 SF (1.53 AC)
(LOTS 1 & 2)

LOT 1

STARBUCK'S LOT AREA (LOT 1) = 21,119 SF (0.48 AC)
STARBUCK'S BUILDING AREA = 1,925 SF
PROPOSED F.A.R. = 0.091
STARBUCK'S IMPERVIOUS AREA = 14,415 SF (71.2%)
STARBUCK'S PERVIOUS AREA = 6,081 SF (28.8%)

LOT 2

FUTURE LOT AREA (LOT 2) = 45,846 SF (1.05 AC)
FUTURE BUILDING AREA = 6,000 SF
PROPOSED F.A.R. = 0.131
FUTURE IMPERVIOUS AREA = 35,352 SF (77.2%)
FUTURE PERVIOUS AREA = 10,494 SF (22.8%)

PARKING DATA

PARKING STALL REQUIREMENT (CLASS B):
10 PARKING STALLS PER 1,000 S.F. OF GROSS FLOOR AREA
1,925 / 1,000 = 1.925 x 10 = 19.25, OR 20 PARKING STALLS REQUIRED
PROPOSED PARKING STALLS = 19
19 < 20. VARIANCE WILL BE REQUIRED.

LOT 2

PARKING STALL REQUIREMENT (CLASS B):
10 PARKING STALLS PER 1,000 S.F. OF GROSS FLOOR AREA
5,900 / 1,000 = 5.900 x 10 = 59 PARKING STALLS REQUIRED
PROPOSED PARKING STALLS = 50
50 < 59. VARIANCE WILL BE REQUIRED.

DRIVE-THRU DATA

STARBUCK'S DRIVE-THRU STACKING = 9 CARS

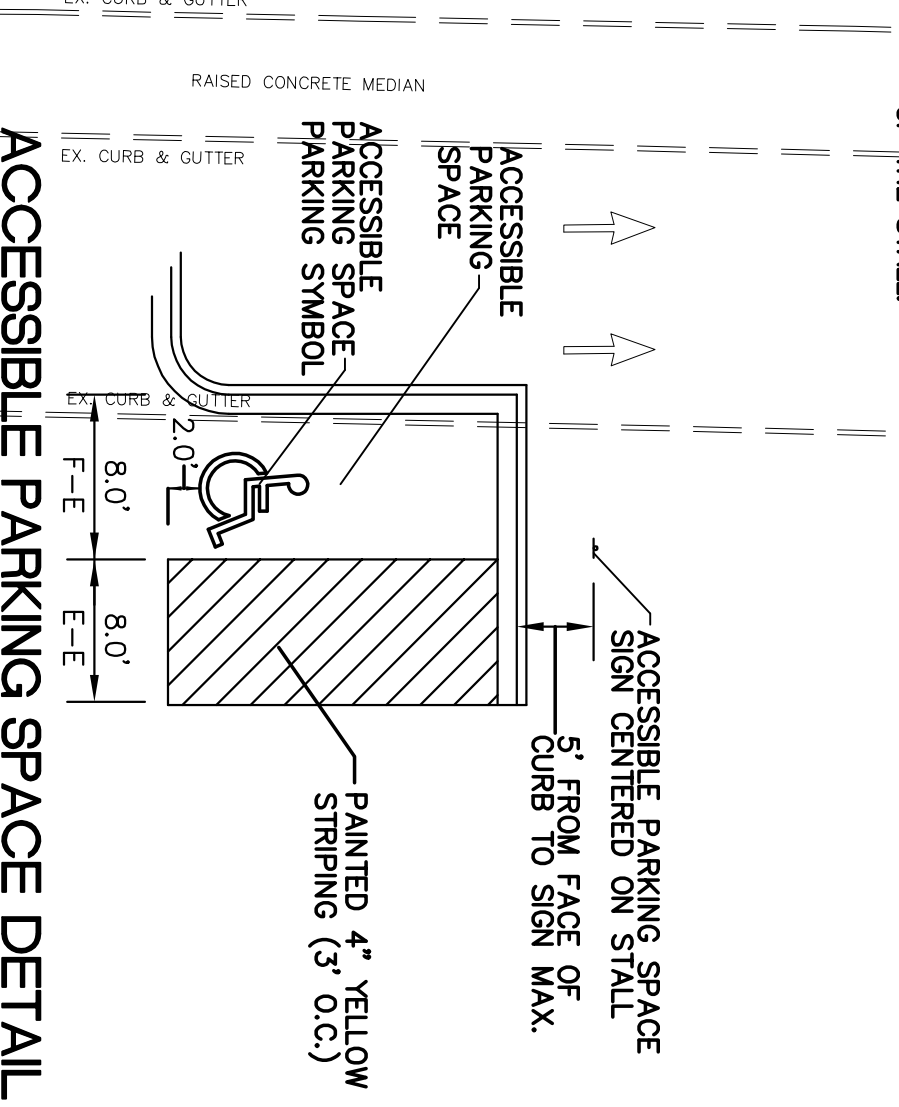

PAVEMENT LEGEND

- SIDEWALK: 5" P.C.C. (SIX BAG MIX) 4" AGGREGATE BASE COURSE (CA-6) COMPACTED SUBGRADE
- STANDARD DUTY: 1 1/2" BITUMINOUS CONCRETE SURFACE COURSE CLASS 1 BINDER COURSE TYPE 2 TYPE "B" 8" AGGREGATE BASE COURSE COMPACTED SUBGRADE
- HEAVY DUTY: 1 1/2" BITUMINOUS CONCRETE SURFACE COURSE CLASS 1 BINDER COURSE TYPE 2 TYPE "B" 10" AGGREGATE BASE COURSE COMPACTED SUBGRADE
- INSIDE TRASH ENCLOSURE & DRIVE-THRU LANE: 8" P.C. CONCRETE WITH 6"x6" NO. 10 WELDED WIRE MESH 4" COURSE (CA-6) COMPACTED SUBGRADE
- OUTSIDE TRASH ENCLOSURE: 2" GALV. STEEL PIPE W/ 1/2" GALV. PLATED BOLTS, NUTS, AND WASHERS SET IN CONCRETE

TRAFFIC AND ACCESSIBLE SIGN

NOTE: TRAFFIC SIGNS TO BE HIGHWAY STANDARD AND TO CONFORM TO CURRENT STATE LOCAL ORDERS AND REGULATIONS

SIGN LEGEND

- STOP SIGN: R1-1 STOP SIGN 30"x30"
- DO NOT ENTER SIGN: R5-1 DO NOT ENTER SIGN 30"x30"

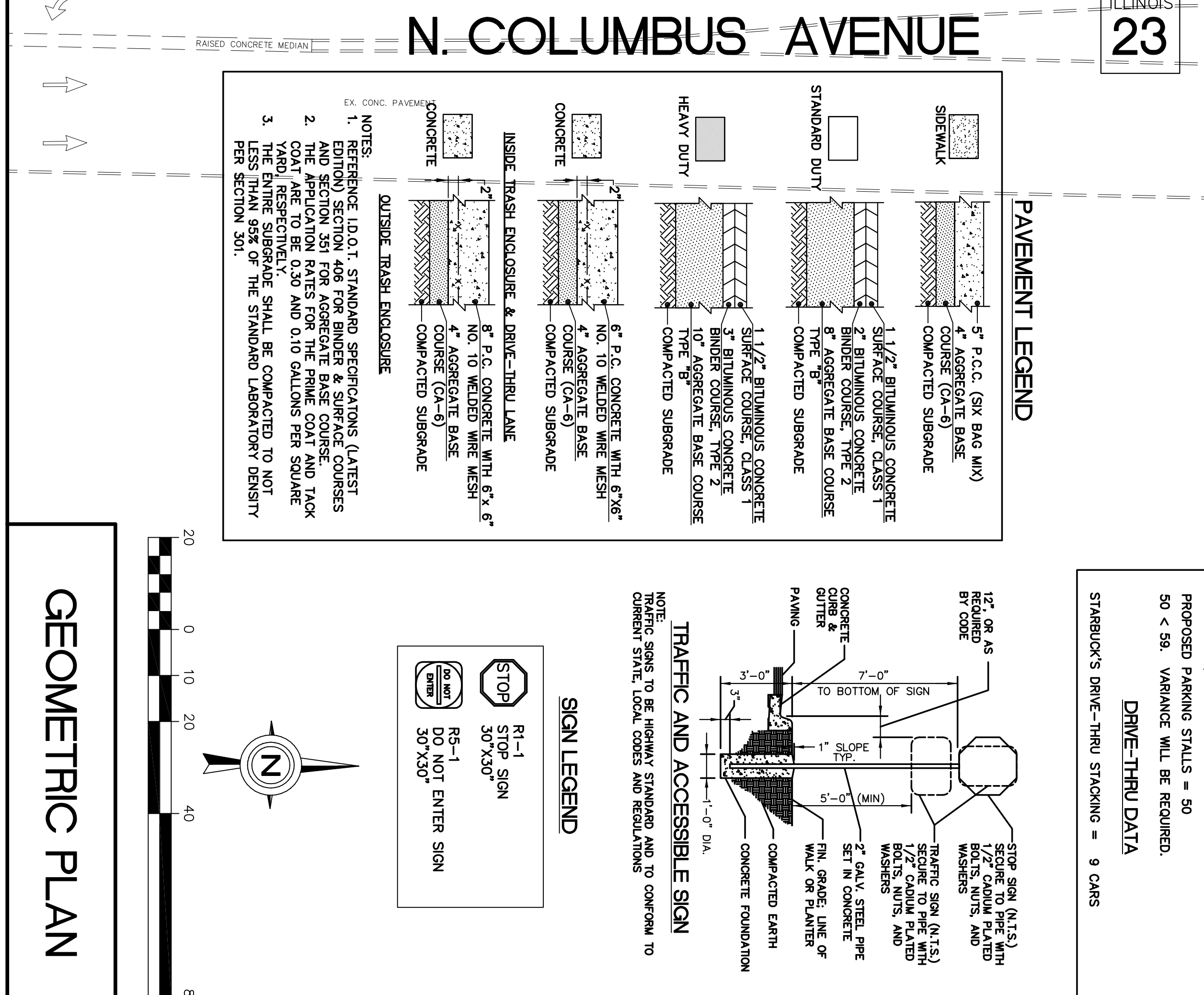

Checked By: J. MILLER
Design By: M. HANSEN
Drawn By: D. SAVAGLIO
Date: SEPT. 21, 2006
Scale: 1" = 20'
Project No.: 05-050

COMPASS
Consulting Group, Ltd.
2631 Ginger Woods Parkway, Suite 100, Aurora, IL 60502
(630)820-9100 FAX: (630)820-7030
www.compassconsultinggroup.com

Prepared For: Capri Development, L.L.C.
208 LaSalle Street, Suite 1144
Chicago, IL 60707
CAPRI DEVELOPMENT - OTTAWA, IL
3005 N. Columbus Avenue
Ottawa, Illinois

NO.	REVISIONS	DATE

Prepared For: C-3